

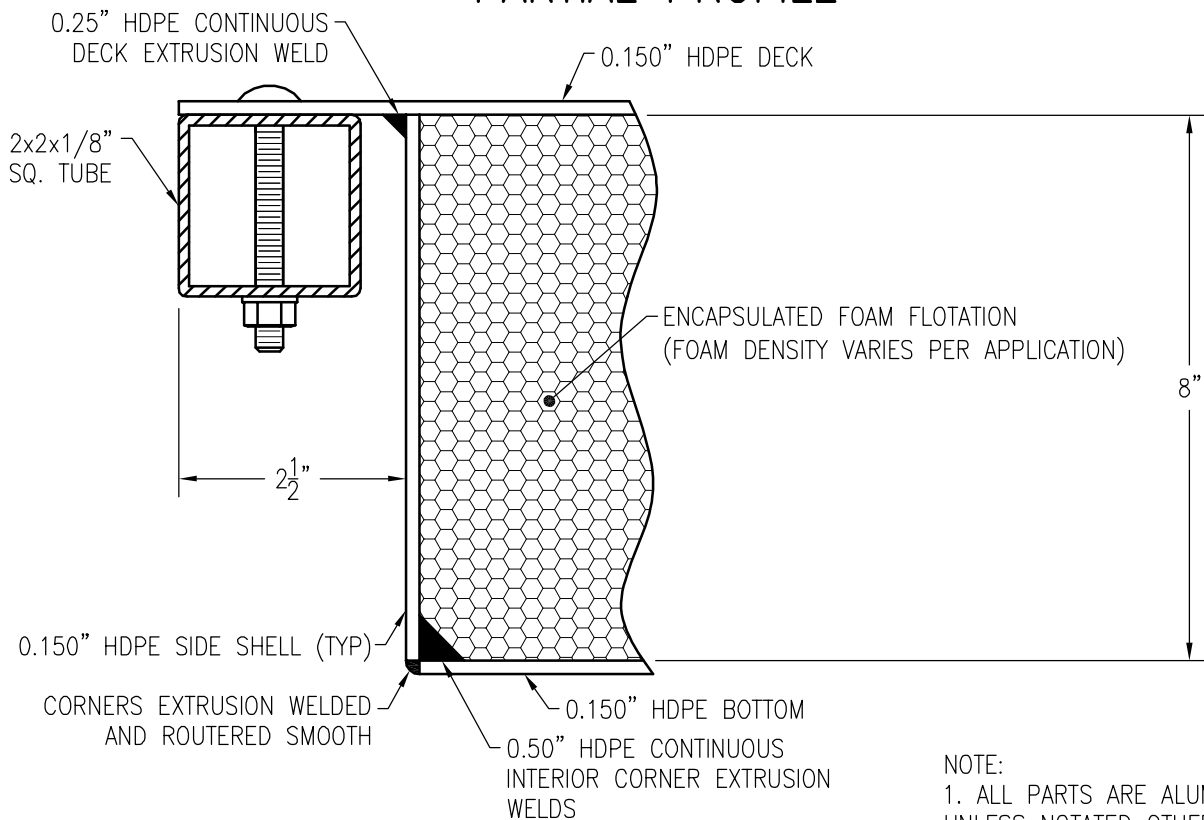

### TYPICAL CORNER PARTIAL PROFILE



NOTE:  
1. ALL PARTS ARE ALUMINUM, UNLESS NOTATED OTHERWISE.

### TYPICAL CORNER PARTIAL SECTION VIEW

ITEM DESCRIPTION: <b>4' x 8' x 8" STANDARD PROFILE FLOAT</b>	DRAWN BY:	C. OLIVER	5/26/10	
	CHECKED BY:	J. HARRISON	5/26/10	
	ITEM NO:	FFLT-0488	5/26/10	
	SCALE:	NOT TO SCALE		
				(954) 785-7557